

# SBS Heat Weld™ Applied Systems Installation Requirements

## Information Sheet



*Quality You Can Trust Since 1886...  
From North America's Largest Roofing Manufacturer™*

# Installation Requirements – SBS Heat-Weld™ Applied Systems:

## Part 1 – General

### 1.01 Work Conditions

- A. Work shall only begin when the contractor has decided, to his satisfaction, that all specifications are workable as specified, and that the contractor can meet project and code requirements.
- B. The contractor shall only begin roofing work when the substrates have been prepared as necessary, and are ready and acceptable to have materials installed as specified.
- C. Do not begin work when inclement weather is forecast to occur prior to the anticipated time of completion of the work item.
- D. Do not install materials during inclement weather, except for temporary work necessary to protect materials that are already installed. Remove all temporary work before installing permanent materials.
- E. Do not install materials when moisture, in any form, is present on the roof deck, or substrate to which the materials are to be applied, or when foaming of hot asphalt occurs.
- F. Protect the building, contents, surrounding area, building occupants and contractor personnel during work.

Coordinate all work operations with the building owner and building occupants so that adequate interior protection, as necessary, is provided and disruption to normal building operations is minimized.

Provide adequate exterior protection to prevent damage to the building owner's property.

- G. Roof system installation should not begin until all roof openings, curbs, pipes, sleeves, ducts, vents or other penetrations through the roof are solidly set, and all tapered edges and cant strips, reglets, and wood nailers are secure and tight to the building as per this specification manual.
- H. Where wheeled or other traffic over the partially completed roofing is unavoidable, provide and use adequate plank or plywood, set over a minimum thickness of rigid board insulation to protect the newly installed roofing.
- I. Provide temporary water cut-offs and tie-ins at the end of each workday. Remove all temporary work at the beginning of the next workday.
- J. When tearing off an existing membrane, limit removal to the area that will be completely reroofed that day with the new roofing system.
- K. If conditions are uncovered or created which would be detrimental to the proper conduct of specified work, immediately notify the building owner and GAFMC of these conditions for consultation on acceptable treatments.
- L. Observe fire and safety precautions as recommended by the Asphalt Roofing Manufacturers Association, the National Roofing Contractors Association, OSHA and this Manual.
- M. All work shall be performed in compliance with local code requirements.

### 1.02 Pre-Job Conference

- A. Potential problems in the application of roofing membranes are best discussed and potential conditions that may be detrimental to installation and performance of the roof system be resolved prior to the start of the application. This can best be accomplished by a pre-job meeting with the architect, roofing contractor, general contractor, all other subcontractors whose work will involve the roof system/related systems and the manufacturer's representative.

B. The following are common items of discussion at a pre-job conference:

1. Roof deck conditions.
2. Flashing and expansion joint details.
3. Insurance underwriters or building code requirements.
4. Unusual project conditions.
5. Protection of the roof, building, building occupants, and contents during and after application.
6. Application techniques.
7. Coordination and scheduling of other trades who will be working on project.
8. Designation by the roofing contractor of a qualified person responsible for quality control. This person shall be on the project full-time during application of the roof system, and shall not be changed without approval of GAFMC.
9. Scheduling of material shipments, material storage, and rooftop loading.
10. Submittals of materials, drawings and project documents.

### 1.03 Delivery, Storage and Handling

- A. GAFMC roofing materials leave the factory dry and must be stored to prevent the materials from getting wet.
- B. Unload and handle all roofing and construction materials with care.
- C. Examine all materials as they are received. Do not use any materials that are damaged, unlabeled or otherwise appear to be unfit for use.

Materials must display legible labels, which identify the materials and applicable reference standards.

Immediately notify carrier and GAFMC or other manufacturer of damaged, wet, or defective materials. GAFMC will not accept responsibility for damage to its roofing materials after the materials have been released from GAFMC manufacturing or warehousing facilities.

- D. Do not expose materials to moisture in any form before, during, or after delivery to the site. Reject delivery of materials that show evidence of contact with moisture.
- E. At the job site, no more material should be stored than will be used within two weeks. For periods longer than two weeks, the materials should be properly warehoused, i.e., dry, ventilated, on pallets, etc. No more material should be stored on the roof than can be used within five days. When prolonged inclement weather threatens, i.e., rainy seasons, no more roofing materials should be supplied to the rooftop than can be used within two days.
- F. Store roll goods on end on pallets in a clean, dry, well ventilated protected area. Take care to prevent damage to roll ends or edges. Do not double stack modified bitumen products.
- G. Remove manufacturer supplied plastic covers from materials provided with such covers. Use “breathable” type covers such as canvas tarpaulins to allow venting and protection from weather and moisture. Cover and protect materials at the end of each day work. Do not remove any protective tarpaulins until immediately before material will be installed.
- H. Lightweight insulation products should be properly stored and weighted to avoid weather and wind damage.
- I. Store roofing asphalt to prevent leakage and carton deterioration.
- J. Store all coatings and sealants/caulks to protect from freezing. Frozen material must be discarded and replaced. Properly seal all liquid material containers after use.
- K. Materials should be stored above 55°F (12.8°C), a minimum of 24 hours prior to application.
- L. Follow the requirements indicated in Part 11 when applying GAFMC membranes at temperatures below 45°F (7.2°C).

- M. In the unlikely event that obviously defective or damaged material reaches the job site or damage to the material occurs from improper storage on the job site, it is the responsibility of the roofing contractor not to install this material. GAFMC should be notified immediately about material that has apparent manufacturing defects. Installation of defective material can result in additional costs above the cost of supplying replacement material. If the roofing contractor chooses to install material with apparent defects, this added cost is not the responsibility of GAFMC.

## 1.04 Regulatory Requirements

- A. Conform to all applicable building and jurisdictional codes, including roof assembly wind uplift and fire resistance requirements.

## 1.05 Quality Control of Application

- A. GAFMC recognizes the crucial role of workmanship in the construction of a reliable roofing membrane designed to perform for its anticipated service life. Material delivery, storage, and handling, and control over material application procedures are also of great importance.
- B. There are recommendations and requirements, which must be considered in the roof system construction process. The following include, but are not limited to:
  - 1. GAFMC recommends that contractors develop and present a verifiable in-house contractor quality control program to the building owner, which can be followed during the construction of GAFMC roof systems.
  - 2. Visual inspection should be of the following: deck surface; specified materials being installed; use of proper bitumen type; conditions of the materials being installed; use of the proper and specified number of fasteners (if required); and that the correct number of plies are being used and that the application procedure is correct; and surfacing.
  - 3. Checks of the asphalt temperatures at all phases of application of underlying roof insulation and base plies.
  - 4. Careful visual examination of all side, end and T-Laps of each ply of Ruberoid® Heat Weld™ membrane for proper adhesion and bitumen bleed out.
  - 5. Architect, owner and contractor shall monitor progress of work for compliance to project specifications and drawings. Such monitoring minimizes the potential for problems, provides for resolution and correction of errors, provides participants with documentation of work in-place, and allows for inspection of work which cannot be examined by standard tests, such as flashing and sheet metal installations. Architect, owner, and general and roofing contractors are responsible for meeting insurance and/or code requirements.
  - 6. Roofing products and other associated roof system materials shall be installed according to the minimum guidelines set forth in this Manual and to individual project requirements.
- C. Contact GAFMC, 1-800-766-3411 for further information about quality control concerns.

## 1.06 Safety Considerations and Warnings

- A. General

Installation of a roof system is a construction process. As with any construction process, safety is a key element. All applicable safety standards and good roofing practices must be followed. Fire prevention is the applicator's responsibility.

- B. Warning

**APPLICATION/USE OF THESE PRODUCTS MAY RESULT IN BURNS, AND/OR OTHER PHYSICAL INJURY. SURFACES, WHICH COME IN CONTACT WITH THE MOLTEN PRODUCT, MAY BECOME INFLAMED. CONTACT WITH MOLTEN ASPHALT MAY CAUSE BURNS.**  
Statement of Practical Treatment: In case of skin contact with molten bitumen, apply ice or other cold liquid compatible with skin. Get medical attention immediately.

## C. General Precautions

- **READ AND UNDERSTAND GAFMC'S SPECIFICATION MANUAL** before starting application. Follow all precautions and direction.
- **Thoroughly train all personnel in the recommended safety procedures** for use of kettles, asphalt mopping, propane torches, and for application of product.
- **FIRE PREVENTION INSPECTIONS** should be conducted periodically during installation, with a final inspection being conducted upon completion of that day's work.
- **THOROUGHLY TRAIN ALL PERSONNEL ON PREVENTING AND EXTINGUISHING FIRES.**
- **NEVER ALLOW CONTACT** between the heated surface of the product, hot asphalt, open flame and hair, skin or clothing.
- **WEAR PERSONAL PROTECTIVE GEAR.** Always use approved safety hardhat, goggles, heavy-duty gloves, snug-fitting clothing (long pants and long sleeved shirt), and boots.
- **SOLVENT-CONTAINING CEMENTS AND COATINGS ARE COMBUSTIBLE AND SHOULD ALWAYS BE KEPT AWAY FROM HEAT, OPEN FLAME, OR ANY SOURCE OF IGNITION.** Empty containers must be disposed in posted toxic substance landfills in accordance with local, state and federal regulations.
- **WHEN WORKING WITH SOLVENT CONTAINING CEMENTS AND COATINGS, AVOID DIRECT CONTACT AND INSURE ADEQUATE VENTILATION.** Wear appropriate protective equipment. Refer to product MSDS for additional information.
- **THOROUGHLY TRAIN ALL PERSONNEL IN FIRST AID PROCEDURES.**
- Always **COMPLY WITH ALL APPLICABLE OSHA SAFETY STANDARDS** and fire codes.
- **NEVER APPLY** built-up or modified bitumen products **DIRECTLY OVER EXPOSED CONDUITS OR PIPES LYING ON THE ROOF DECK.**
- Use **extreme caution** when working around equipment, such as gas lines or HVAC units, which have electrical and/or gas connections.

## D. TORCH SAFETY INFORMATION

1. Installation of torch-applied products creates the **risk of fire**, including smoldering fires. Torch applied products must be applied only by professional roofing applicators trained in proper torch application and safety procedures. Roofing applicators must follow GAFMC's current roofing safety requirements, procedures and specifications, which are available from GAFMC Contractor Services, toll free 1-800-766-3411.
2. Procedures and equipment that will be used must comply with all applicable code requirements. Knowledge of the building construction and HVAC systems must be obtained prior to installation of torch-applied products.
3. Identify all potentially combustible and flammable aspects of the buildings use and design that increase the risk of fire including:
  - Deck and under deck composition (materials and accessories);
  - Insulation types;
  - Cants and tapered edge strips;
  - Parapet wall and curb composition;
  - Perimeter details;

- Adjoining building materials;
  - Expansion joints;
  - Wires and electrical conduit pipes;
  - Natural gas lines;
  - Chemicals, grease, oil or other condensates/exhausts/spills.
  - Restaurant and food service exhaust vents can contain grease. All intake fans should be **shut off** during application with special care to keep open flame away from openings and vents. Exhaust vents for laundromats in commercial, institutional structures, or residential condominiums, apartments and other multiple tenant occupied dwellings can contain lint and debris.
4. A fiberglass base sheet must be used between the roofing membrane and any combustible materials such as wood. Repair any damaged or torn base sheets before torch welding begins. Combustible materials, substrates and adjoining building surfaces that cannot be removed from torch welding area must be protected. **Never apply flame directly to combustible materials or allow the flame to enter into hidden or protected areas** that may contain combustible materials such as:
- Air intakes or exhaust openings;
  - Air coolers and A.C. units;
  - Lead flashings;
  - Drains;
  - Counter-flashings and coping covers;
  - Collars;
  - Flashings.
5. The installation equipment must be designed for the specific use, and must be in proper working order. Follow the manufacturer's safety and operating instructions for all torching equipment. Check all fittings and other equipment for leakage. **Never use a flame to check fittings and other equipment.** Ventilation must always meet or exceed OSHA or NIOSH requirements.
6. A supervisor trained in torch safety must **conduct external and internal fire watches** during application and after the torches are shut down. Infrared scanning equipment must be used in the fire watch. The watches shall never be less than one hour and may need to be longer. The watches shall be of sufficient frequency and duration based on:
- Weather;
  - Building and roof design and composition;
  - Penetration types and design.
7. One Class ABC fire extinguisher must be kept within 10 feet of every torch operator. In addition, buckets of sand and pails of water are recommended as supplemental fire extinguishing materials. Portable fire extinguishers must be of a size and type required by local codes, however, extinguishers less than a 20 lb. minimum size are not recommended. Fire extinguishers must be checked prior to each day's work to make sure they are full and operable.

The above list is not a complete set of necessary safety requirements, procedures, and specifications. Call GAFMC Contractor Services for the most current technical literature. In addition, **the following steps must be taken** by the applicator to prevent fires, since only the applicator is in a position to prevent fires. These steps include, but are not limited to:

- Do not leave propane torches **lighted and unattended**. Do not **place a lighted torch on** the deck surface, insulation, membrane, or any other surface or object other than **an acceptable torch stand**.
- **Extinguish** the torch **when not in use**.

- **Avoid** holding the flame on any one area of the membrane or substrate long enough for **heavy smoke** to be generated.
- Train all personnel in GAFMC recommended application techniques.
- Torch operators must maintain awareness of other personnel in the torch welding area. In tight quarters, only one torch should be used.
- Train all personnel in fire prevention and extinguishing methods.
- **Take precautions when working around combustible materials**, such as gas lines for HVAC units, and in the presence of solvent-based products. Remove all combustible debris, material wrappers and trash from torch welding area prior to installation. Use **caution to prevent burns and train personnel in first aid procedures**.
- Comply with all applicable fire regulations regarding the storage and use of propane.

For more information on safety measures, refer to the Asphalt Roofing Manufacturers Association titled Torch “Applied Roofing Do’s and Don’ts” and their video, “A Guide to Safety Torch-On Modified Bitumen”. Asphalt Roofing Manufacturers Association, 4041 Powder Mill Road, Suite #404, Calverton, MD. 20705-3106, (301) 231-9050. Also refer to Factory Mutual Property Loss Prevention Data Sheet 1-33.

## Part 2 - Inspection and Preparation of Surfaces

### 2.01 General

- A. Prepare substrate surfaces thoroughly prior to application of new roofing materials. This is particularly important for recover and reroofing applications. Providing a smooth, even, sound, clean and dry substrate minimizes the likelihood that underlying deficiencies will cause premature deterioration or even failure of the new roofing system.

### 2.02 Roof Decks

- A. The surface of the roof deck must be dry, firm, smooth, and free of dirt and loose material. Electrical conduits, bolts, and other similar small items must be removed from the surface of the roof deck; such surface irregularities cannot be properly insulated and roofed. It is the responsibility of the roofing contractor, deck contractor, and owner’s representative to determine the suitability of the roof deck surface to receive the roof assembly. The deck must meet GAFMC requirements, as described in the Roof Design section of this manual. None of the foregoing factors are the responsibility of GAFMC, which under no circumstances will assume such responsibility.
- B. Perimeter and penetration wood nailers and curbs must be in place as specified.
- C. The roof deck must provide positive drainage or tapered insulation must be used to provide slope. Outlets must be placed and installed to remove water promptly and completely from the roof.
- D. Expansion joints, roof vents, roof drains, etc., must be installed using acceptable industry standards and GAFMC specifications.

### 2.03 Recover Systems

- A. For recover specifications (installation of a new roofing system over an existing system), additional surface preparation relative to inspection and treatment of defects in the existing roofing system must be conducted in accordance with good roofing practices. Preparation includes, but is not limited to, removal of existing flashings, replacement of wet/damaged existing roofing materials, removal of loose aggregate, removal of abandoned equipment, supports and penetrations, replacement of damaged decking, etc. The substrate must present a suitable surface to receive and hold the new roofing materials. Also refer to GAFMC recommendations on reroofing in the Roof Design section of this manual.

Blisters, splits, other membrane defects and deck deficiencies must be repaired, and wet insulation replaced in accordance with good roofing practices to attain a surface which is smooth, dry, clean and free of sharp projections and depressions.

- B. If the existing roof membrane is to remain on the roof and there is any doubt as to the adequacy of the attachment of the existing roof membrane, then the new roof membrane should be mechanically fastened through the existing roof to the deck. Stainless steel fasteners are recommended when fastening through existing roof systems.
- C. A recovery board must be used over the old roof membrane if an existing roof is not a smooth surface or if adhered gravel is to remain. Power broom, spud if necessary and remove all loose gravel to provide a smooth, level surface. Mechanically fasten cover board to deck.
- D. All existing composition and metal flashing must be removed and replaced.
- E. All metal counter flashing, metal coping and other metal work above the roof system must be inspected, and replaced or repaired as necessary to provide a watertight assembly.
- F. All metal flashing must be primed where it will come in contact with the GAFMC membranes.
- G. Inspect roof drains and outlets. Remove existing drain flashings and replace broken or stripped bolts, clamping rings and strainers. Drains must be Mweld® drains or drains with metal type clamping rings. Plastic drains are not acceptable. All drains, including retrofit or insert drains, must be sumped to promptly remove water from the roof surface.
- H. Mweld™ one way Mvent moisture vents must be used when recovering. Install a minimum 4" (10.2 cm) diameter one way pressure relief vent every 10 squares (92.9 m<sup>2</sup>). Cut 4" (10.2 cm) holes for one way vents through the existing roof system to the deck. For roof systems where the minimum dimension does not exceed 60 feet, perimeter venting may be used in place of the one way vents.
- I. If a vapor retarder exists, contact GAFMC Contractor Services at 1-800-766-3411.
- J. When reroofing over an existing coal-tar roof system, a minimum 1" (25 mm) recover board is required over the existing system.
- K. All existing surfaces must be compatible with GAFMC roof systems. Prime all masonry, metal and existing asphalt surfaces and substrate with asphalt primer where GAFMC membranes are to be adhered.
- L. Contact GAFMC at: 1-800-766-3411 for requirements on individual projects and recover over non-asphaltic based roofing systems.

## 2.04 Reroofing-Tear-off

- A. All old roofing must be removed down to the deck. The deck shall be cleaned, repaired, and otherwise conditioned to conform to the requirements of a new deck. Refer to the Roof Design section of this manual.
- B. All old flashing must be removed and stripped from all walls, curbs, etc.
- C. All existing composition and metal flashing must be removed and replaced.
- D. All metal counter-flashing, metal coping and other metal work above the roof system must be inspected, and replaced or repaired as necessary to provide a watertight assembly.
- E. All metal flashing must be primed where it will come in contact with the GAFMC membranes.
- F. Prime all masonry, metal and existing asphalt surfaces and substrate with asphalt primer where GAFMC membranes are to be adhered.
- G. Inspect roof drains and outlets. Remove existing drain flashings and replace broken or stripped bolts, clamping rings and strainers. Drains must be Mweld® drains or drains with metal type clamping rings. Plastic drains are not acceptable. All drains, including retrofit or insert drains, must be sumped to promptly remove water from the roof surface and meet code requirements.

**Note:** Substrates must be inspected and accepted by the deck contractor, roof contractor or owner as being ready to receive and hold the roof system as specified.



## Part 3 – Asphalts

### 3.01 General

- A. Hot asphalt must be handled carefully. See Section 1.06 Safety Consideration and Warnings.
- B. Field experience has demonstrated that proper temperatures in the kettle and at the point of application are essential to obtain a satisfactory roof. Kettle temperatures in excess of those indicated below may result in changes to the asphalt, while temperature below specified minimums can result in lack of adhesion.
- C. Do not mix different types of asphalt.
- D. Take all necessary precautions to avoid asphalt drippage into the interior of a building. GAFMC will not be responsible for damage to the structure or interior because of asphalt drippage.
- E. Discontinue application of asphalt over any substrate where foaming of asphalt is observed.
- F. **Ruberoïd® Heat-Weld™ membranes are designed for torch application to approved substrates and underlying base plies and must not be installed in moppings of hot asphalt.** References to use of hot asphalt within these specifications refer solely to installation of other roof components such as vapor retarders, roof insulation, and underlying base plies as applicable and required by GAFMC specifications.

### 3.02 Asphalt Type

- A. Only use an ASTM D-312, Type III or Type IV Asphalt. **Type IV asphalt must be used for roofing systems on all slopes  $\frac{3}{4}$ " per foot (6.2 cm per meter) or greater.**
- B. Only use asphalt manufactured in the United States or Canada, unless otherwise approved in writing, by a GAFMC Contractor Services Manager.

### 3.03 Asphalt Application Rate

- A. Application with hot asphalt requires continuous, uniform interply mopping rates of 25 lbs.  $\pm$  20% per 100 square feet of roof area (1.2 kg/m<sup>2</sup>). Too little asphalt may result in voids, while too much asphalt can result in membrane slippage.
- B. When applying non-modified glass base or glass interply sheets, the point of application temperature of the asphalt must be at the Equiviscous Temperature (EVT) with a tolerance of  $\pm$  25°F (13.9°C), at which a viscosity of 125 centistokes is attained. When using mechanical asphalt applicators, the target viscosity should be 75 centistokes.
- C. The equiviscous temperature (EVT) for the asphalt can be found on the asphalt cartons or bills of lading.
- D. For substrates that absorb asphalt, apply the asphalt in sufficient quantity to assure the level of adhesion specified.
- E. Asphalt application shall not commence when the outside temperature is below 45°F (7.2°C) unless cold weather application instructions are followed. See Part 11.
- F. In cold weather insulated piping and ladders may be necessary to maintain the required asphalt temperature at the point of application.

### 3.04 Asphalt Heating

- A. The operator of the roofing bitumen kettle must be fully trained and familiar with its safe operation and have the required safety equipment and clothing for his protection.
- B. Never leave the roofing bitumen kettle unattended while operating.

- C. Accurate thermometers must be on the job site to check temperatures at the kettle and at point of application.
- D. Do not heat the asphalt to the or above its flash point.
- E. Do not hold the asphalt at temperatures above the finished blowing temperature for more than 4 hours.
- F. Do not keep heated tankers above 325°F (163°C) overnight or weekends.
- G. The roofing bitumen kettle must be placed a safe distance from the building. It should be on plywood or a tarp to facilitate easy clean up.











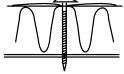

## **Part 4 – Fastening**

### **4.01 General**

- A. GAFMC recommends the use of tools and equipment specifically designed for mechanically fastening roof materials to conform to requirements of the fastener manufacturer.
- B. Drive fasteners at an appropriate angle to insure proper thread engagement and specified holding strength. Fasteners that are improperly installed shall be removed or corrected.
- C. Do not drive fasteners to the point where the stress plates cup and insulation “dimples”. This is indicative of over driving the fastener.
- D. Do not drive fasteners to the point where the head of the fastener is left exposed above the stress plate. This is indicative of under driving the fastener.
- E. Fasteners must be installed to secure the roof assembly to the structural substrate to provide a recommended minimum wind uplift resistance equal to FMRC 1-60. Where design requirements, local code, insurance or other regulatory requirements dictate higher wind resistance values, a design professional must advise of fastener type and density.
- F. Do not install fasteners into/through wet or deteriorated insulation and/or substrates.
- G. Stainless steel fasteners are recommended when fastening through existing roof systems.
- H. Be sure to locate and identify electric or any other conduits in or under decks, and/or walls before any drilling is performed.
- I. Fastener pullout tests are required for poured lightweight insulating concrete, gypsum and cementitious structural wood fiber decks.
- J. Fastener pullout tests are recommended for all deck types.
- K. Metal or plastic stress plates, minimum 3” (7.6 cm) in diameter, are required when mechanically attaching insulation or the base sheet and insulation simultaneously. Metal stress plates must be used for torch or heat weld applications.
- L. For additional fastening information, and for FM compliance, refer to Factory Mutual LPDS 1-7, 1-28, 1-29 and 1-49; also refer to the Factory Mutual Approval Guide and GAFMC Factory Mutual Approval Reports for supplemental information.

## 4.02 Fastener Types

GENERAL FASTENER TYPES		
DECK TYPE	FASTENER TYPES	
	Base Sheet	Insulation
Steel		A
Wood	B,C	C
Concrete	D,E	D,E
Gypsum (Poured)	F, G, H, I	K
Gypsum (Plank)	F, G	K
Lightweight/Cellular Insul. Concrete	I	K
Structural Wood Fiber	G, J, K	K

<b>A</b>		<b>B</b>			<b>C</b>		<b>D</b>		<b>E</b>		
	Steel Fastener-Self Tapping Screw		Capped Head Nail 1" dia. rnd. or sq. cap	Roofing Nail Annular Thread 3/8" dia. 11ga.		Wood Fastener Self Tapping Screw min. 3" Plate		Concrete Fastener Spiral Fluted Shank		Concrete Fastener Threaded min. 3" Plate	
<b>F</b>		<b>G</b>		<b>H</b>		<b>I</b>		<b>J</b>		<b>K</b>	
	Hardened Split Shank Nail		Tube Nail Two Piece 1" dia. cap		Hollow Cone Shank Fastener		LWC Base Ply Fastener		Self-Locking Fastener 1" dia. cap		Two Piece Nylon Screw and Plate

- A. DRILL-TEC™ Screw and plate for steel. Carbon steel fastener with corrosion resistant coating, self-tapping drill point, driven through a minimum 3" (7.6 cm) plate, or stainless steel fastener, self-tapping, driven through a minimum 3" (7.6 cm) plate.
- B. Cap Head Nail – 1" (25 mm) diameter round or square cap, smooth shank or annular threaded. Roofing Nail – 3/8" (10 mm) diameter head/11 gauge, smooth shank or annular threaded; must be driven through minimum 1" (25mm) round/square cap plate.
- C. DRILL-TEC™ Screw and plate for wood. Carbon steel fastener with corrosion resistant coating, self-tapping, driven through a minimum 3" (7.6 cm) plate.
- D. DRILL-TEC™ Spiral Fluted Shank concrete Fastener – driven through a 3" (7.6 cm) plate.
- E. DRILL-TEC™ Screw and plate for concrete. Carbon steel fastener with corrosion resistant coating, driven through a minimum 3" (7.6 cm) plate.
- F. Hardened Split Shank Nail – when driven, shank spreads out to provide back-out resistance.
- G. Two-Piece Tube Nail – 1" (25 mm) diameter cap; when driven, pin bends/hooks out to provide back out resistance. Stress plates are optional.
- H. One piece self-locking hollow cone shank fastener – electro-zinc galvanized tapered cone shank.

- I. DRILL-TEC™ LWIC Base Ply Fastener – when driven, electro-zinc galvanized shank spreads out to provide back out resistance. Some installations may require fastener to be driven through 3" (7.6 cm) plate.
- J. Self-Locking Fastener – 1" (25 mm) diameter cap, when driven, shank spreads out to provide pullout resistance.
- K. DRILL-TEC™ Nylon Screw and Plate – two-piece reinforced nylon screw and plate system with deep slotted, self-locking thread design; with 3" (7.6 cm) metal plate.

Refer to GAFMC list of approved fasteners for those fasteners that must be used in GAFMC guaranteed roofing system. A copy of this list is available from GAFMC at 1-800-766-3411.

## **Part 5 – Vapor Retarder Installation**

### **5.01 General**

- A. The best vapor retarder material cannot be effective in reducing transmission of moisture vapor if it is not properly installed or if it is damaged or punctured during the time of application. Laps and joints must be properly sealed, projections extending through the vapor retarder must be flashed or enveloped at the vapor retarder level to insure integrity of the vapor retarder, and all punctures in the vapor retarder must be repaired prior to installation of the roof insulation. Insulation boards should be installed immediately over the vapor retarder to protect the vapor retarder from punctures or damage caused by subsequent construction traffic.
- B. When a vapor retarder is installed, allow for venting any trapped gases between the vapor retarder and the roof membrane by using perimeter venting or by using one-way vents placed one vent for every 1,000 square feet, venting from the surface of the vapor retarder.

### **5.02 Steel Decks**

- A. Install the vapor retarder over a minimum layer of non-isocyanurate insulation of sufficient thickness to span the deck flutes:

**NOTE:** See comment in the Roof Design section of this manual regarding insulation thicknesses/"R" values required for this construction.

#### **1. Bottom Insulation Layer**

Mechanically attach the bottom insulation layer as specified in Part 7.

#### **2. Vapor Retarder**

- a. Starting at the low point of the roof, chalk line the surface of the bottom layer of insulation to serve as guides for the proper mopping and laying of the vapor retarder plies, then install two plies of GAFGLAS® Ply 4 or GAFGLAS® FlexPly™ 6 felt over the insulation. Install 19 11/16" (50 cm) and 39 3/8" (100.0 cm) widths and follow with a second full 39 3/8" (100.0 cm) width sheet with a maximum of 17 11/16" (44.9 cm) exposure, applied shingle style. Lap felts 20 11/16" (52.6 cm) with an 18 11/16" (47.5 cm) exposure and lap 4" (10.2 cm) on ends. Stagger adjacent end laps a minimum of 18" (45.7 cm). Install the felts in full and uniform mopping of hot asphalt applied at the rate of 25 lb/square (1.2 kg/m<sup>2</sup>) ± 20%.

#### **3. Top Insulation Layer**

Install the next and subsequent insulation layer in hot asphalt as specified in Part 7.

## 5.03 Non-Nailable Decks

### A. Vapor Retarder

1. Prime the deck with asphalt primer (ASTM D41) applied at the rate of 1 gal/square (0.41 L/m<sup>2</sup>) minimum or as required by the primer manufacturer.

For precast and prestressed concrete decks,

- a. Hold primer application back 4" (10.2 cm) from panel joints, cracks or roof openings. Allow the primer adequate time to dry.
  - b. Over the panel joints, install a minimum 8" (20.3 cm) strip of GAFGLAS® #75 centered over the joint and spot attached on one side to the deck with hot asphalt.
2. Starting at the low point of the roof, install two plies of GAFGLAS® Ply 4 or GAFGLAS® FlexPly™ 6 felt over the deck. Install 19 11/16" (50 cm) and 39 3/8" (100.0 cm) widths and follow with a second full 39 3/8" (100.0 cm) width sheet with a maximum of 17 11/16" (44.9 cm) exposure, applied shingle style. Lap felts 20 11/16" (52.6 cm) with an 18 11/16" (47.5 cm) exposure and lap 4" (10.2 cm) on ends. Stagger adjacent end laps a minimum of 18" (45.7 cm). Install the felts in full and uniform mopping of hot asphalt applied at the rate of 25 lb/square (1.2 kg/m<sup>2</sup>) ± 20%.
  3. Install insulation in hot asphalt as specified in Part 7.

## 5.04 Wood and Structural Wood Fiber Decks

### A. Vapor Retarder

Install vapor retarder over sheathing paper on the deck, starting at the low point of the roof. Refer to Part 4 of this Section for fastener types applicable to the roof deck type:

1. First Ply: Mechanically fasten one ply of GAFGLAS® #75 using fasteners approved for applicable deck type.

Lap the base sheet 2" (5.1 cm), and mechanically fasten with three rows of fasteners. The first row (on the seam) will be 1" (2.5 cm) from the leading edge and on 9" (22.9 cm) centers. Locate the second row of fasteners 14" (35.6 cm) from the leading edge and on 18" (45.7 cm) centers. The third row of fasteners shall be 26" (66.0 cm) from the leading edge on 18" (45.7 cm) centers. The centers for the second and third rows should be staggered.

2. Second Ply: Install GAFGLAS® Ply 4 or GAFGLAS® FlexPly™ 6 in a full and uniform mopping of hot asphalt applied at the rate of 25 lb/square (1.2 kg/m<sup>2</sup>) ± 20%. Lap the ply sheet 2" (5.1 cm) at side laps and 4" (10.2 cm) on end laps.
3. Install insulation in hot asphalt as specified in Part 7.

## 5.05 Lightweight Insulating Concrete or Poured Gypsum Decks

- ### A. Vapor Retarder (Note: Installation of insulation over new lightweight insulating concrete with or without a vapor retarder is not recommended.)

1. First Ply: Mechanically fasten one ply of Stratavent® Eliminator™ Nailable Base Sheet using fasteners approved for lightweight insulating concrete decks. Lap the base sheet 2" (5.1 cm), and mechanically fasten with three rows of fasteners. The first row (on the seam) will be 1" (2.5 cm) from the leading edge and on 9" (22.9 cm) centers. Locate the second row of fasteners 14" (35.6 cm) from the leading edge and on 18" (45.7 cm) centers. The third row of fasteners shall be 26" (66.0 cm) from the leading edge on 18" (45.7 cm) centers. The centers for the second and third rows should be staggered. For FMRC approved fastening patterns refer to the current FMRC Approval Guide.

2. Second Ply: Install GAFGLAS® Ply 4 or GAFGLAS® FlexPly™ 6 in a full and uniform mopping of hot asphalt applied at the rate of 25 lb/square (1.2 kg/m<sup>2</sup>) ± 20%. Lap the ply sheet 2" (5.1 cm) at side laps and 4" (10.2 cm) on end laps.
3. Install insulation in hot asphalt as specified in Part 7.

## **Part 6 – Steep Slope (<sup>3</sup>/<sub>4</sub>" per Foot and Greater) Requirements**

### **6.01 General**

- A. Use ASTM D-312, Type IV asphalt must be used on slopes of <sup>3</sup>/<sub>4</sub> inch per foot (6.2 cm per meter) or greater.
- B. Slippage of mop applied roof systems may occur on slopes of <sup>3</sup>/<sub>4</sub> inch per foot (6.2 cm per meter) or greater. Supplemental fastening is therefore required. If the roof slope is less than <sup>3</sup>/<sub>4</sub> inch per foot (6.2 cm per meter), supplemental fastening is not required.
- C. Use treated wood nailers (insulation stops) at least 3 1/2 inches (8.9 cm) wide and equal in thickness to the insulation. Nailers must be mechanically fastened to the deck installed at right angles to the direction of the slope.
- D. On ridges where insulation stops are required, treated wood nailers must be a minimum 3-1/2 inches (9 cm) wide and equal in thickness to the insulation. Nailers shall be secured mechanically to the deck on both sides of the ridge. Where nailers meet, bevel edges to form a flush surface for membrane application.

### **6.02 Wood Nailers on Slopes of 3/4" but Less than 2" per Foot**

- A. If slope is <sup>3</sup>/<sub>4</sub> inch per foot or more but less than 2 inches per foot (6.2 cm but less than 16.7 cm per meter), use wood nailers at the eave, at the ridge and at intermediate points of no more that 16 feet (4.9 m). All dimensions are from inside face to inside face of the wood nailers.
- B. Ensure a snug fit with the courses of insulation, but avoid cutting the insulation where possible.
- C. For non-insulated nailable decks, back-nail the plies directly to the deck at the intervals listed.
- D. For non-insulated, non-nailable decks, set the wood nailers flush with decks and install at the intervals as indicated.

### **6.03 Wood Nailers on slopes of 2" to 3" per Foot**

- A. If slope is 2 inches per foot to 3 inches per foot (16.7 cm to 25.0 cm per meter), use wood nailers at the eave, at the ridge and at intermediate spacing of no more than 8 feet (2.4 m). All dimensions are from inside face to inside face of the wood nailers.
- B. Ensure a snug fit with the courses of insulation, but avoid cutting the insulation where possible.
- C. For non-insulated nailable decks, back-nail the plies directly to the deck at the intervals listed.
- D. For non-insulated, non-nailable decks, set the wood nailers flush with decks and install at the intervals as indicated.

### **6.04 Wood Nailers on Slopes Greater than 3" per Foot**

- A. For roofs with slopes greater than 3 inches per foot (25.0 cm per meter), contact GAFMC Contractor Services at 1-800-766-3411.

## 6.05 Insulation Installation

- A. If insulation is to be installed, mechanically attach insulation or mop between wood nailers.

## 6.06 Membrane Installation

- A. Install all plies of base and ply sheets vertically on slopes  $\frac{3}{4}$  inch per foot (6.2 cm per meter) or more and back-nail them into wood nailers or nailable decks approximately 1 inch (2.5 cm) from the leading edge of the sheets. All end laps must be at wood nailers and blind nailed into the wood nailer on 8-inch center (20.3 cm). Use nails with integral metal heads at least 1 inch (25mm) round or square.
- B. At ridges, base plies must extend across opposite sides of ridge, over the nailer and be fastened on 8-inch (20.3 cm) centers. An additional layer of base sheet shall be centered over the ridge overlapping the fasteners at least 6 inches (15.2 cm).
- C. Install Ruberoid® membranes vertically on slopes of  $\frac{3}{4}$  inch per foot and greater. Terminate membrane at wood nailer and fasten the top edge of each sheet with screws and 3-inch (7.6 cm) plates on 8-inch (20.3 cm) centers across the top of the sheet. The overlapping sheet must extend at least 9 inches (22.9 cm) past the top of the underlying sheet. All end laps must be staggered to the closest wood nailer, spaced a minimum of 4 feet (1.22 m). On slopes of 2 inches to 3 inches per foot (16.7 to 25 cm per meter), the Ruberoid® sheets must be cut into length not to exceed 17 feet (5.18 m). For non-insulated wood decks, terminate and fasten the end of the Ruberoid™ sheets to the deck with the same fasteners, on the same spacing indicated above.
- D. At ridges, cap sheet must extend across opposite sides of ridge over the nailer and be fastened with screws and 3-inch (7.6 cm) plates on 8-inch (20.3 cm) centers. An additional full width ply of cap sheet shall be centered over the ridge to form a ridge cap overlapping the fasteners at least 6 inches (15.2 cm).

## Part 7 – Insulation Installation

### 7.01 General

- A. Do not apply roof insulation and roofing until all other work trades have completed jobs that require them to traverse the deck on foot or with equipment. A vapor retarder (membrane type) coated lightly with asphalt may be applied to protect the inside of the structure before the insulation and final roofing are installed. Before the application of the insulation, the vapor retarder must be carefully repaired.
- B. Do not install wet, damaged or warped insulation boards.
- C. Install insulation boards with staggered board joints in one direction (unless taping joint).
- D. Install insulation board snugly. Gap between board joints must not exceed  $\frac{1}{4}$ " (6 mm). All gaps in excess of  $\frac{1}{4}$ " (6 mm) must be filled with like insulation material.
- E. Do not kick insulation boards into place.
- F. Install insulation boards per insulation board manufacturer's requirements.
- G. Edges of insulation board shall be mitered and filled at ridges and elsewhere to prevent open joints or irregular surfaces. Avoid breaking or crushing of the insulation at the corners.
- H. Do not install insulation over old lightweight insulating concrete deck without the use of a vapor retarder. Do not install insulating concrete over new lightweight insulating concrete.
- I. Steel decks require mechanical attachment of insulation using DRILL-TEC™ screws and plates.

- J. Insulation boards must be mechanically fastened or attached with hot asphalt to the deck. Refer to the Roof Design section of this manual. Do not attach with cold adhesive, unless approved in writing by GAFMC Regional Contractor Services Manager.
- K. The insulation must be securely attached to the roof deck. A minimum FMRC 1-60 attachment is recommended. Refer to FMRC Approval Guide for FM fastening patterns. Factory Mutual requires fastener density increased in corner areas for FM 1-60, and perimeter, and corner area fastener density increases for FM 1-90 or greater. Refer to FM Loss Prevention Data Sheets 1-7, 1-28, and 1-49.
- L. Use only fasteners with a minimum 3 inch (7.6 cm) stress plate when mechanically attaching insulation.
- M. Do not attach insulation with nails.
- N. A maximum board size of 4' by 4' (1.22 m x 1.22 m) is to be used if the insulation is to be adhered in asphalt.
- O. Do not install any more insulation than will be completely waterproofed each day.
- P. Preservative treated wood insulation stops/nailers, the same thickness as the insulation, shall be attached at outside edges and openings through the deck. Refer to Part 2, Item 2.02, of this Section.
- Q. If tapered roof insulation is to be installed all hip and valley panels must be mitered. Laced valleys are not acceptable.
- R. Never torch Ruberoid® Heat-Weld™ membranes directly to roof insulation.

## 7.02 Additional Layers of Insulation

- A. Install additional insulation layers, maximum 4' x 4' (1.22m x 1.22m) board size, in full and uniform moppings of hot asphalt applied at the rate of 25 lbs./square (1.2 kg/m<sup>2</sup>) ±20%. Press each board firmly into place. Stagger the joints of each additional layer by as much as possible in relation to the insulation joints in the layer(s) below (minimum 6"(15.2 cm) stagger) to eliminate continuous vertical gaps.
- B. As an alternate method to the above, multiple layers of the same non-tapered insulation material may be simultaneously mechanically fastened with approved fasteners and plates through the top layer of insulation to the structural deck. Individual layers of insulation must not exceed 3" (7.6 mm) in thickness, nor may total thickness of all layers should not exceed 5" (12.7 cm) without written approval of GAFMC Contractor Services. GAFMC and FMRC approved perlite or wood fiberboard insulation, minimum 1/2" (13 mm) thickness, may be installed over one or more layers of approved polyisocyanurate roof insulation simultaneously attached. Stagger and offset all joints of each insulation layer from underlying layers.

Fastening pattern and uplift classification for simultaneously attached insulation assemblies is dependent upon the top layer of insulation directly under the fastener plates according to the listed FMRC approval for the specific insulation material, deck type and fastener assembly used. Refer to FMRC Loss Prevention Data Sheet 1-28 and 1-29 for additional requirements and information.

## 7.03 Roof Tape

- A. Roof tape, if required over insulation joints, shall be laid evenly, smoothly and embedded in a uniform coating of hot steep asphalt with 4" (10.2 cm) end laps. Be careful to assure smooth application of tape, and full embedment of the tape in the asphalt.
- B. Application of the asphalt and tape may be made by either "back mopping" the tape and pressing the tape into place, or by use of tapping machine (small felt layer) which will apply asphalt to the tape in a continuous operation.



## Part 8 – Membrane System Installation

### 8.01 General

- A. Substrates must be inspected and accepted by the contractor as suitable to receive and hold roof membrane materials.
- B. Start the installation of all membrane plies at the low point or drains, so the flow of water is over or parallel to the ply laps, but never against the laps.  
  
Position and align roll prior to application.
- C. Chalk lines where necessary to assure proper alignment and headlap widths of membrane plies.
- D. Use half base sheet width as a starter strip in two-ply roof constructions.
- E. Installation of all membrane plies, except those that are mechanically fastened, shall result in a visible, uniform flow-out of bitumen at side and end laps.
- F. Assure that all membrane plies lay flat and are uniformly secured to their substrate. Wrinkles, fish mouths and similar defects must be removed and patched.
- G. Extend all membrane plies to dimensions necessary to accommodate flashing conditions shown in the Flashing Details of this section.
- H. All lap edges for GAFMC cap membranes shall be rolled-in or walked-in immediately after installation. Additional care must be taken to insure complete bonding at T-laps. Lap edges on all membrane sheets should be inspected for full and uniform bonding to the underlying membrane sheet.
- I. Stagger all adjacent end laps for all membrane plies a minimum of 18" (45.7 cm). **Side laps shall not coincide with underlying plies in multiple layer applications.**
- J. Prime all masonry, metal and existing asphalt surfaces and substrate with asphalt primer where insulation or GAFMC membranes are to be adhered. Primer (ASTM D 41) shall be applied at the rate of 1 gal/square (0.41 L/m<sup>2</sup>) minimum or as required by primer manufacturer. Allow the primer adequate time to dry.
- K. Brooming-in of glass felts is vital to minimize voids and assure complete, uniform attachment.
- L. Occasionally, a roll of felt or membrane will contain a splice that was fabricated as part of the manufacturing process. These splices are marked. Cut out all splices, and treat as an end lap.
- M. Back nailing of felts and cap sheets, and the use of ASTM D-312 Type IV asphalt is required on slopes <sup>3</sup>/<sub>4</sub>" per foot (6.2 cm per meter) or greater. Refer to Part 6, "Installation on Steep Slope <sup>3</sup>/<sub>4</sub>" per Foot and Greater".
- N. Ruberoid® Heat-Weld™ membranes are intended for use with Ruberoid® Heat-Weld™ flashing membranes and should not be mixed with APP materials. Ruberoid® Heat-Weld™ membranes may be used with compatible asphalt based built-up roofing systems as flashing materials.

### 8.02 Phasing

- A. The term "phasing" refers to the practice of applying part of a total roof membrane at one time and allowing that part to remain exposed to the weather for a period of time before applying the remaining elements of the roof system. Membranes applied in this manner are subject to early deterioration. Blisters, voids, membrane damage and moisture infiltration are much more likely to occur in "phased" roof membranes.
- B. GAFMC does not approve the practice of "phasing".

- C. Whenever it is necessary to put a building “in the dry” quickly, a temporary roof covering is recommended; this temporary roof must be removed prior to installation of the roof system.

### 8.03 Base Sheets – Mechanically Fastened

- A. After allowing the base sheet to relax, keep sheet taut, fastening at center of sheet and working in opposite directions. Push all wrinkles and buckles ahead as fastening proceeds.

The following are minimum fastening patterns, that may be used when fastening the base ply. For FMRC approved fastening patterns, refer to the current FMRC Approval Guide.

1. Base sheet (no insulation) on decks of wood, plywood, OSB, lightweight concrete, gypsum, or cementitious wood fiber (Figure 1).

Lap the base sheet 2" (5.1 cm), and mechanically fasten with three rows of fasteners. The first row (on the seam) will be 1" (2.5 cm) from the leading edge and on 9" (22.9 cm) centers. Locate the second row of fasteners 14" (35.6 cm) from the leading edge and on 18" (45.7 cm) centers. The third row of fasteners shall be 26" (66.0 cm) from the leading edge on 18" (45.7 cm) centers. The centers for the second and third rows should be staggered.

2. Simultaneous fastening base sheets with insulation, with the DRILL-TEC™ fasteners having a 3" (7.6 cm) plate (Figure 2):

Lap the base sheet 2" (5.1 cm). Screws and plates are then installed in 3 equally spaced rows on 24" (60.1 cm) inch maximum centers in each row. One row is in the 2" (5.1 cm) side lap, the other rows are located equidistant from the lap rows approximately 12" – 13" (30.5 - 33.0 cm) from the lap rows. This pattern results in approximately one fastener per 2.1 square feet (0.2 meter). Along building perimeters (minimum 4 foot wide) fastening pattern must be increased to one fastener per 1.2 square feet (0.11 meter), 4 equally spaced rows of fasteners on 18" (45.7 cm) centers.

**Note:** When fastening base sheets using screws and plates without insulation, the plate must be of a design that allows it to lie flat on the deck.

Figure 1

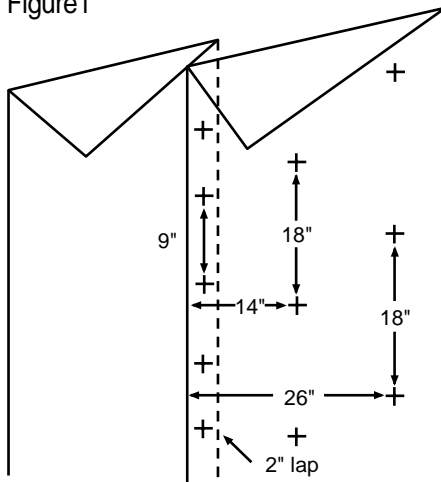
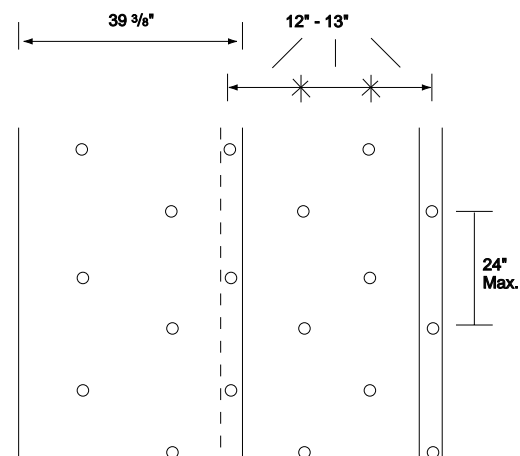

Figure 2



## 8.04 Base/Interply Sheets – Hot Asphalt Application

### A. General

The following applies to all GAFMC sheets, which may be used as ply sheets or base sheets excluding Stratavent® Eliminator™ Perforated Venting Base Sheet.

Foot and machine traffic on freshly applied membranes with asphalt must be kept to a minimum to reduce the possibility of asphalt displacement due to “point applied” pressure. The potential result is the creation of an area where the asphalt quantity may be too light to perform the required waterproofing function.

Workmen must stand on the insulation, or deck side of the system and avoid traffic on the freshly laid membrane system for a long enough time to allow the asphalt to set up. Do not allow equipment over, or store materials, on the freshly laid membrane. Asphalt dispensing equipment must have balloon tires.

- B. For slopes under  $\frac{3}{4}$ " per foot (6.2 cm per meter), Type III or IV asphalt can be used. Type IV must be used on all slopes  $\frac{3}{4}$ " per foot (6.2 cm per meter) and greater.
- C. Asphalt shall be applied in a uniform layer, without voids, at a rate of 25 lb/square (1.2 kg/m<sup>2</sup>) ±20%. See Part 3 “Asphalt”.
- D. Base sheet: Install full width base sheets, lapping 2" (5.1 cm) on the sides and 4" (10.2 cm) on ends. Stagger adjacent end laps a minimum of 18" (45.7 cm) apart.
- E. One-ply interply application: Install full width interply sheets, lapping 2" (5.1 cm) on the sides and 4" (10.2 cm) on ends. Stagger adjacent end laps a minimum of 18" (45.7 cm) apart. Where installed over base sheet, stagger ply sheet side and end laps from underlying plies.
- F. Two-ply interply applications: Install 19- $\frac{11}{16}$ " (50 cm) and 39- $\frac{3}{8}$ " (100.0 cm) width starter plies, and follow with a second 39- $\frac{3}{8}$ " (100.0 cm) width sheet with a maximum of 17- $\frac{11}{16}$ " (44.9 cm) exposure, applied shingle style. Lap sheets 20- $\frac{11}{16}$ " (52.6 cm) with an 18- $\frac{11}{16}$ " (47.5) exposure and 4" (10.2 cm) on end laps. Stagger adjacent end laps a minimum of 18" (45.7 cm).
- G. Three ply interply applications: Install starter strips of 13- $\frac{1}{8}$ " (33.3 cm), 26- $\frac{1}{4}$ " (66.7 CM) and 39- $\frac{3}{8}$ " (100.0 cm) widths and follow with a second full 39- $\frac{3}{8}$ " (100.0 cm) width sheet with a maximum 11- $\frac{1}{8}$ " (28.3 cm) exposure, applied shingle style. Lap sheets 26- $\frac{15}{16}$ " (68.4 cm) with a 12- $\frac{7}{16}$ " (31.6 cm) exposure and lap 4" (10.2 cm) at ends. Stagger adjacent end laps a minimum of 18" (45.7 cm).
- H. Four-ply interply applications: Install starter strips of 9- $\frac{7}{8}$ " (25.1 cm), 19- $\frac{11}{16}$ " (50 cm), 29- $\frac{1}{2}$ " (74.9 cm) and 39- $\frac{3}{8}$ " (100.0 cm) widths and follow with a second full 39- $\frac{3}{8}$ " (100.0 cm) width sheet with a maximum 7- $\frac{7}{8}$ " (20 cm) exposure, applied shingle style. Lap sheets 30- $\frac{1}{16}$ " (76.4 cm) with a 9- $\frac{5}{16}$ " (23.6 cm) exposure and lap 4" (10.2 cm) at ends. Stagger adjacent end laps a minimum of 18" (45.7 cm).
- I. Apply asphalt so that a small bead of asphalt shows at the edge of the membrane. Do not allow heavy flows of asphalt to extend beyond the membrane edge. Heavy, irregular surface flows of asphalt will make proper application of cap membrane difficult.
- J. In the event a wrinkle or a “fishmouth” forms during the application of the membrane, do not “walk it down” as the memory of the sheet or felt may cause it to reappear. Fishmouths or wrinkles shall be sliced open and patched with hot asphalt and additional membranes. Avoid cutting into the plies below the fishmouth or wrinkle by angling the knife blade to the side.

## 8.05 Stratavent® Eliminator™ Perforated Base Sheet

**Note:** **DO NOT** torch apply Ruberoid® Heat-Weld™ membranes directly to Stratavent® Eliminator™ Perforated Venting base sheet. At least one ply of GAFGLAS® #75 Base Sheet **MUST** be hot mopped over the Stratavent® Eliminator™ Perforated Venting base sheet before torch applying Ruberoid® Heat-Weld™ membranes

- A. Roll Stratavent® Eliminator™ Perforated Base sheet out dry, granule-surface down, directly over isocyanurate insulation, asphalt-primed smooth structural concrete or existing smooth-surfaced built-up roofing.
- B. Lap base sheet 2" (5.1 cm) on the sides and 4" (10.2 cm) on the ends, with adjacent end laps a minimum of 18" (45.7 cm) apart.
- C. Install the subsequent system ply/plies in hot asphalt over the Stratavent® Eliminator™ Perforated Base Sheet. The hot asphalt used to install the subsequent ply/plies mopped over the surface of Stratavent® Eliminator™ Perforated Base Sheet flows through the perforations to attach the base sheet and membrane system to the substrate.

## 8.06 Ruberoid® Heat-Weld™ Membrane Application

- A. Do not install of Ruberoid® Heat-Weld™ membranes without careful review and implementation of all relevant safety and fire watch requirements including materials / combustible substrates review, LP-Gas equipment storage and handling guidelines, worker safety precautions and training. Refer to Part 1.06 Safety Considerations and Warnings for additional recommendations and safety precautions.
- B. The surface over which the membrane is to be installed must be clean, smooth, dry and prepared in accordance with this specification manual. Do not apply Ruberoid® Heat-Weld™ membranes directly to a fresh asphalt glaze or flood coat, or over base plies with excessive asphalt mopping bleed out at laps.
- C. Do not install Ruberoid® Heat-Weld™ membranes over base plies or materials installed with solvent based cold adhesives or mastics.
- D. For slopes  $\frac{3}{4}$ " per foot (6.2 cm per meter) and over, Ruberoid® Heat-Weld™ must be run vertically, parallel to roof slope and back nailed in accordance with Part 6, "Installation on Steep Slope  $\frac{3}{4}$ " per Foot and Over." For slopes less than  $\frac{3}{4}$ " per foot (6.2 cm per meter), install cap sheet perpendicular to slope.
- E. Cap sheet application: Install full width cap sheets, lapping 3" (7.6 cm) on the sides and 6" (15.2 cm) on ends. Stagger adjacent end laps a minimum of 18" (45.7 cm) apart. All side and end laps must be staggered from underlying plies.
- F. Never apply Ruberoid® Heat-Weld™ membranes by any method except welding with a propane torch or other equipment specifically designed for application of SBS modified bitumen.
- G. The coiled membrane must be unrolled approximately 10 ft. (3 meters), aligned, then the propane torch flame applied uniformly across the exposed back surface of the membrane and lap areas until the compound reaches the proper application temperature and exhibits a slight sheen. Be sure that there is complete burn-off of release films where present on the underside of the rolls, membrane selvage edges or both surfaces as applicable. Avoid over-heating which may result in damage to or improper adhesion of the membrane. (The flame should be moved from side to side in the shape of an "L", applying about 75% of the heat to the membrane and 25% to the substrate or underlying plies including the lap area of the previously installed courses.) The membrane is slowly unrolled as heat is applied to ensure proper adhesion. When complete, re-roll the opposite end of the membrane and install in the same manner.
- H. A minimum 1/16" (2 mm) asphalt flow-out must be obtained at all seam areas. Dry laps are not acceptable. To ensure the proper bead of bitumen at the seam areas, an GAFMC Roller may be used. Roller application should follow behind the torch no more than 4 ft. (1.2 m) nor less than 3 ft. (0.91 m) to be sure that the membrane will be at the proper temperature to produce proper flow. Hand rollers or "walking-in the seam" methods are also acceptable. Check all seams for full and uniform adhesion. Un-adhered seams must be lifted with a heated trowel and resealed by lightly torching the seam area.

- I. Matching granules may be broadcast into the modified bitumen bleed out at seams while hot to enhance the finished appearance of the membrane. It is not required for issuance of a GAFMC Guarantee.
- J. All end laps must be staggered a minimum of 18" (45.7 cm) so that no adjacent end laps coincide. If end laps fall in line or are not staggered the proper distance, a full width of Ruberoid® Heat-Weld™ membrane must be installed over the end laps. End laps, flashing sheets and other seams formed over granule surfaces require pre-heating of the top surface of the underlying granule surface membrane to a point where the granules just begin to sink into, and the modified bitumen compound comes up through the granules to ensure proper seam construction and adhesion.
- K. All laps must be parallel or perpendicular to the slope of the roof such that the flow of water is never against the lap.
- L. SBS membranes must not be applied during adverse weather or without precautionary measures in temperatures below 45°F (7.2°C). Refer Part 11 for additional information on Cold Weather Precautions.

## **Part 9 – Flashing**

### **9.01 General**

- A. Refer to the construction details in this section, which depict flashing requirements for typically encountered conditions. Install flashing materials as shown in the construction details.
- B. Base flashing for roof systems to be guaranteed for 15 years must be a minimum two ply construction. A ply of GAFGLAS® #75 Base Sheet, extending the full height of the base flashing must be installed under the Ruberoid® Heat-Weld™ granule surfaced membrane top ply.

Base flashing for roof systems to be guaranteed for 20 years must be a minimum two ply construction. A ply of Ruberoid® Heat-Weld™ 25 membrane, extending the full height of the base flashing must be installed under the Ruberoid® Heat-Weld™ granule surfaced membrane top ply.

Refer to the Flashing Specifications Plates for flashing designations and guarantee length eligibility.

- C. Basic wood blocking anchorage recommendations are found in Factory Mutual Data Sheet 1-49. These recommendations are required for Factory Mutual approved projects.
- D. All penetrations should be at least 18" (45.7 cm) from curbs, walls, and edges to provide for proper flashing.
- E. Install flashing sheets starting at low points.
- F. Where indicated by GAFMC construction details, install base sheets and backer plies in Type III or IV hot asphalt. Maintain asphalt at EVT +/- 25°F (13.9°C) for all base and ply sheets used in flashing details. Never use solvent based flashing cements, adhesives, mastics and coatings in conjunction with Ruberoid® Heat-Weld™ membranes.
- G. Prime all metal and masonry with Matrix™ asphalt primer and allow to dry before being fully adhered to with flashing sheets.
- H. Only use GAFMC membranes in construction of flashing details.
  - I. Do not use metal base flashing. Damage to the roofing system caused by metal base flashing is not the responsibility of GAFMC.
  - I. Base flashing should extend a minimum of 8" (20.3 cm), and a maximum of 24" (61 cm) above the roofline.
- J. Corner membrane flashings, such as "bow ties" for outside corners and "footballs" for inside corners or other membrane reinforcements are required to ensure that base flashing corners are sealed at cant areas. Alternate

method of the corner reinforcing: install a smooth MB membrane reinforcement piece on the prepared corner substrate prior to final surfacing membrane. Refer to MB Flashing Details section.

Note: Mastic and fabric coursing is not an acceptable alternate for proper flashing and counter-flashing details.

## 9.02 Cant Strips and Wood Nailers

### A. Cant strips

1. BMCA Perlite Cant strips must be installed at the intersection of the roof and all walls, parapets, curbs, or transitions approaching 90°, that are to be flashed. They shall be approximately 4" (10.2 cm) in horizontal and 4" (10.2 cm) in vertical dimension. The face of the cant shall have an incline of not more than 45° with the roof.
2. Wood cants shall be solid and pressure treated for rot resistance. Perlite based cant strips must comply with ASTM C-728. Do not use fiberboard cants for torch grade installations. Use solid wood cants when mechanical securement to cants is required or when solid wood cants will help stabilize the vertical wood nailers at projections or expansion joint openings.
3. Masonry cants shall be integrally cast to the wall and deck. They shall be finished and prepared with the same care as the deck. The cant shall be constructed so that it provides a vertical offset equal in thickness to the roof insulation.
4. Do not use metal cant or metal curb strips.
5. Cants shall always be installed on top of the roof insulation, or wood nailers.
6. Mechanically fasten cant where applicable. Otherwise, set in hot asphalt and install as shown in "Flashing Details", in this section. Do not use Trowel Grade Modified Adhesive with Ruberoid® Heat-Weld™ membranes.
7. Neatly fit all joints and miters.

### B. Wood Nailers

1. Wood nailers must be 3 1/2" (8.9 cm) minimum width or 1" (25 mm) wider than metal flange and minimum 1" (25 mm) thick and securely fastened to the deck.
2. Wood nailers shall be the same thickness as tapered edge strip or insulation.
3. For roof systems requiring perimeter venting, nailers shall be slotted.

## 9.03 Sheet Metal

- A. Metal should not be used as a component of base flashing. Because of the high coefficient of expansion of sheet metals and the large temperature changes that can be experienced on a roof, sheet metal or exposed metal components must be isolated from the waterproofing components of the roofing and flashing system as efficiently as possible to prevent the metal from splitting the membranes.

GAFMC assumes no responsibility for damage to the roofing system caused by the movement of accessory metal.

- B. When it is unavoidable to use metal in the roofing system (i.e., lead flange at drains, gravel stops), treated wood nailers and insulation stops, 1" (.5 mm) wider than the metal flange, should be provided for metal flange securement.

For Ruberoid® Heat-Weld™, set metal flange in softened membranes (torch heated), and secure with fasteners of the same type metal as the flange. The metal flange is then sealed using the applicable construction detail to meet guarantee requirements.

Metal accessories (gravel stops, counter flashing, etc.) should be a minimum 16 oz. (0.56 mm) copper, 24 gauge (0.71 mm) galvanized or stainless steel, 2 1/2 to 4lb (1.1-1.8 kg) lead, or 0.032" (0.81 mm) aluminum.

- C. Fabricate and install all sheet metal materials as shown in applicable construction in the Flashing Detail Section. Refer to SMACNA (Sheet Metal and Air Conditioning Contractors National Association, Inc.) for guidance on sheet metal treatments not addressed in this Manual.
  - D. Clean metal and apply asphalt primer to all sheet metal surfaces that will come into contact with asphalt or other bituminous materials; allow the primer adequate time to dry.
  - E. Use fastener types compatible with the sheet metal type.
    - 1. Copper or lead-coated copper: use copper or bronze fasteners.
    - 2. Lead and galvanized steel: use galvanized or cadmium-plated sheet fasteners.
    - 3. Aluminum: use aluminum fasteners.
    - 4. Stainless steel: use stainless steel fasteners.
  - F. Metal counter-flashing shall have a minimum 4" (10.2 cm) face with a drip lip. The bottom edge of the counter-flashing shall cover the roofing membrane and/or base flashing by a minimum of 4" (10.2 cm). Metal counter-flashing used for masonry walls, wooden walls or through wall metal flashings should be two piece design to allow for installation and later removal. Metal counter-flashings for stucco, EIFS, wood siding or similar materials should be designed to receive and set as a base for those materials, such as "Z" type flashing, while providing for securement of separate metal counter-flashing to cover base flashings. Metal end joints shall be lapped 3" (7.6 cm) or more. Adequate fasteners must be provided to secure against effect of wind forces. Skirt fasteners shall be watertight.
  - G. Metal termination bars shall be a minimum of 1/10" (3 mm) thick x 1" (2.5 cm) wide with preformed sealant edge lap. Bar should have 1/4" (6 mm) x 3/8" (10 mm) slotted holes on 4" (10.4 cm) centers to facilitate mechanical anchorage.
- Note:** Termination bars are not suitable in all base flashing and wall flashing conditions. Termination bars may only be used in conjunction with an appropriate counter-flashing extending a minimum of 4" (10.2 cm) below the termination bar.
- H. Metal flanges for gravel stops, eave strips and pitch pockets to be used in conjunction with roofing shall be primed (both sides). For Ruberoid® Heat-Weld™ roof systems set metal flanges in softened membranes (torch heated), and nail 4" (10.2 cm) o.c. to wood nailers or insulation stops.

Flanges shall be a minimum of 3 1/2" (8.9 cm) wide for gravel stops or eave strips and 4" (10.2 cm) wide for projections and extensions through the roof. The gravel stop or eave strip riser shall be at least 3/8" (10 mm) high for modified bitumen or smooth surface built-up roofing. Total height of riser should be adjusted to extend just above the finished surface, including gravel surfacing if present.

Provision must be made for securing the skirt to the face of the wall. This may be wood nailer strips for masonry and metal construction. In all cases, gravel stop and eave strip nailer should be fastened to the deck or deck system with adequate resistance against wind forces.

- I. Stacks shall have metal sleeve flashing a minimum 8" (20.3 cm) high. Pitch pockets for brackets, supports, pad-eyes, etc., shall have a 4" (10.2 cm) minimum height metal sleeve.
- J. On reroofing projects, provisions shall be made for reinstallation of existing sheet metal duct work, equipment, coping metal and counter-flashings removed in conjunction with the new work. Also provide for cleaning and repairing of existing defective sheet metal, and replacement of missing and irreparable sheet metal to match existing types. Light gauge sheet metal flashings which are incorporated into the Ruberoid® Heat-Weld™ roof system are not suitable for re-use and must be replaced with new material.

- K. Conduits and piping such as electrical and gas lines must be set on wood blocking or some other form of support. Wood blocking/supports must be set on doubler pads (an additional layer of the roof membrane).

## 9.04 Ruberoid® Heat-Weld™ Flashing Membrane Application

- A. Ruberoid® Heat-Weld™ membranes used for flashing material can only be installed using a propane torch or other equipment intended for heat weldable SBS materials.
- B. Refer to the construction details in this section
- C. Wood curbs and walls must be covered with a layer of approved GAFMC base sheet or backer ply of selected two-ply flashing system and fastened 8" (20.3 cm) o.c. in all directions with approved fasteners with minimum 1" diameter or square caps. All vertical laps shall be 4" (10.2 cm). Base sheet or backer ply must extend out onto field of roof as shown in applicable GAFMC construction detail.
- D. Backer plies installed over masonry or other non-nailable substrates in hot asphalt must be cut into manageable lengths to ensure adequate adhesion to cant strip and vertical surfaces without excessive voids. All vertical laps shall be 4" (10.2 cm). Backer ply shall extend out onto field of roof as shown in applicable GAFMC construction detail.
- E. It is recommended that the finished ply of base flashing be run vertically to provide a selvage edge that will aid in achieving proper adhesion at the 3" (7.6 cm) vertical laps. If the sheet is run horizontally, the vertical laps must be a minimum of 6" (15.2 cm) and the salvage edge must be removed from the sheet or fully covered by the counter-flashing. The finished flashing ply shall extend out onto the field of the roof as shown in the applicable GAFMC construction detail, and must be extended a minimum of 4" (10.2 cm) beyond the edge of the prior flashing plies. The flashing must be soundly adhered to the parapet, cant area and roof surface to result in a minimum void, non-bridging construction.
- F. Torch Method Application:
  1. Measure and cut Ruberoid® Heat-Weld™ membrane into the required lengths.
  2. Apply the propane torch flame uniformly across the back surface of the membrane and lap areas until the compound reaches the proper application temperature and exhibits a slight sheen. Be careful during application to ensure the complete burn-off of release films where present on the underside of the rolls, membrane selvage edges or both surfaces as applicable. Avoid overheating which may result in damage to or improper adhesion of the membrane. (The flame should be moved from side to side in the shape of an "L", applying about 75% of the heat to the membrane and 25% to the substrate or underlying plies including the lap area of the previously installed courses.) The membrane is slowly unrolled as heat is applied to ensure proper adhesion. Immediately nail the top of the flashing as specified in flashing detail to prevent slippage.
  3. Membrane flashing sheets may be either back torched and set into position, or rolled and torched into position as the flashing sheet is uncoiled. Flashing sheets must be carefully pressed into place to ensure full adhesion to the substrate and backer plies. Laps must be rolled or pressed to ensure proper seaming with a minimum 1/16" (2 mm) bead of bitumen at all seams.

## Part 10 – Surfacing

### 10.01 General

- A. Install all surfacing to provide proper membrane, wind uplift and fire protection as required by GAFMC in conjunction with local code, insurance and project requirements.
- B. Surfacing weights must be considered when determining the load capacity of the structural support system's ability to handle the completed roof installation and other expected loads. GAFMC is not responsible for determining load capacities, and recommends that a certified professional make any determination relative to load bearing capacity of a structure.
- C. Ruberoid® Heat-Weld™ Smooth membrane is not covered with factory applied surfacing granules and must receive protective surfacing of asphalt and gravel within 30 days after completion.



- D. Ruberoid® Heat-Weld™ membranes with factory applied granule surfacing do not require additional surfacing materials. Do not use liquid surface coatings over these membranes when new.
- E. GAFMC shall not be liable or responsible for ballast and paver surfacing systems.

## 10.02 Gravel and Asphalt

- A. GAFMC does not permit gravel surfacing of Ruberoid® Heat-Weld™ roof membrane systems on slopes greater than 1 inch per foot (8.3 cm per meter).
- B. Not less than 400 lb/square (19.5 kg/m<sup>2</sup>) of gravel or 300 lb/square (14.6 kg/m<sup>2</sup>) of slag shall be applied in a flood coat of 60 lb/square (2.9 kg/m<sup>2</sup>) of hot asphalt.
  - 1. Gravel at the time of application shall be hard, durable, opaque and free of clay, loam, sand or other foreign substances and comply with the ASTM D 1863.
- C. Asphalt shall conform to the latest revision of ASTM D 312 Type III or IV and may be used on slopes up to 3/4" per foot (8.3 cm per meter). ASTM D 312 Type IV must be used on slopes of 3/4" per foot to 1" per foot (8.3 cm per meter).
- D. No more asphalt shall be applied at one time than can be immediately covered with gravel or slag.

## 10.03 Walkways

- A. Walkways for normal rooftop traffic can be constructed from two plies of Ruberoid® Heat-Weld™ modified bituminous membranes. This type of walkway is not for sidewalk or patio-type use.
- B. Construct walkways prior to the application of field surfacing by solidly torch adhering a first ply of smooth surfaced membrane to the field of the roof and then adhering a top ply of granule surfaced membrane to the surface of the first ply.
- C. Walkway sections should be no longer than 10' (3m), with a 6" (15.2 mm) minimum gap between each section to allow for drainage.
- D. Surface the roof around and between the pads if additional surfacing is added to the GAFMC membrane.

## Part 11 – Cold Weather Application Precautions

- A. In cooler weather, unrolling and relaxing modified bitumen rolls and base sheet rolls prior to installation will reduce the potential for wrinkles to form in the finished roof. The rolls can be cut into shorter lengths for easier handling when rerolling and installing.
- B. Special care is required when installing GAFMC roof membranes at temperatures below 45°F (7.2°C):
  - 1. The roof substrate must be dry. There must be no ice, dew or water.
  - 2. All membrane rolls, adhesives and coatings must be stored for at least overnight at a minimum temperature of 55°F (12.8 °C) prior to their application. All water-based coatings must be protected from freezing at all times.
  - 3. Remove rolls from the heated storage only as they are being installed. Install membrane rolls immediately after removal from storage to avoid membrane cooling. Modified rolls must be at least 45°F (7.2°C) at time of application.
  - 4. For non-modified glass felts, the asphalt temperature at point of application must be maintained at the asphalt's EVT. The use of insulated asphalt handling equipment is recommended in cold weather. Do not

over heat the asphalt to try to offset the cold ambient temperature. If the proper asphalt application temperature can not be consistently maintained, roofing must be discontinued. Be aware that cool, windy conditions will cause asphalt heat loss to occur at a rate equivalent to a lower ambient temperatures.

5. Mopping must not precede the roll by more than five feet.
6. If insulation is being set in mopping asphalt, it must be set quickly while the asphalt is still hot and fluid. Use the minimum insulation size available. At no time should boards larger than 4' X 4' (1.22 X 1.22 m) be set in hot asphalt.
7. Do not overheat Ruberoid® Heat-Weld™ rolls to compensate for cold ambient temperatures.